

A guide to select the correct bell-housing and drive coupling components

DATA REQUIRED

Electric motor power/motor size
 Manufacturer and pump type

TO VERIFY:

- 1 - Pump and motor shaft dimensions (see page 69)
- 2 - Shaft and flange pump (see pump data sheet)

Example:

- Electric motor 2 kW - 4 poles - Motor size 110/112
- Atos pump code PFE31 - Shaft 1

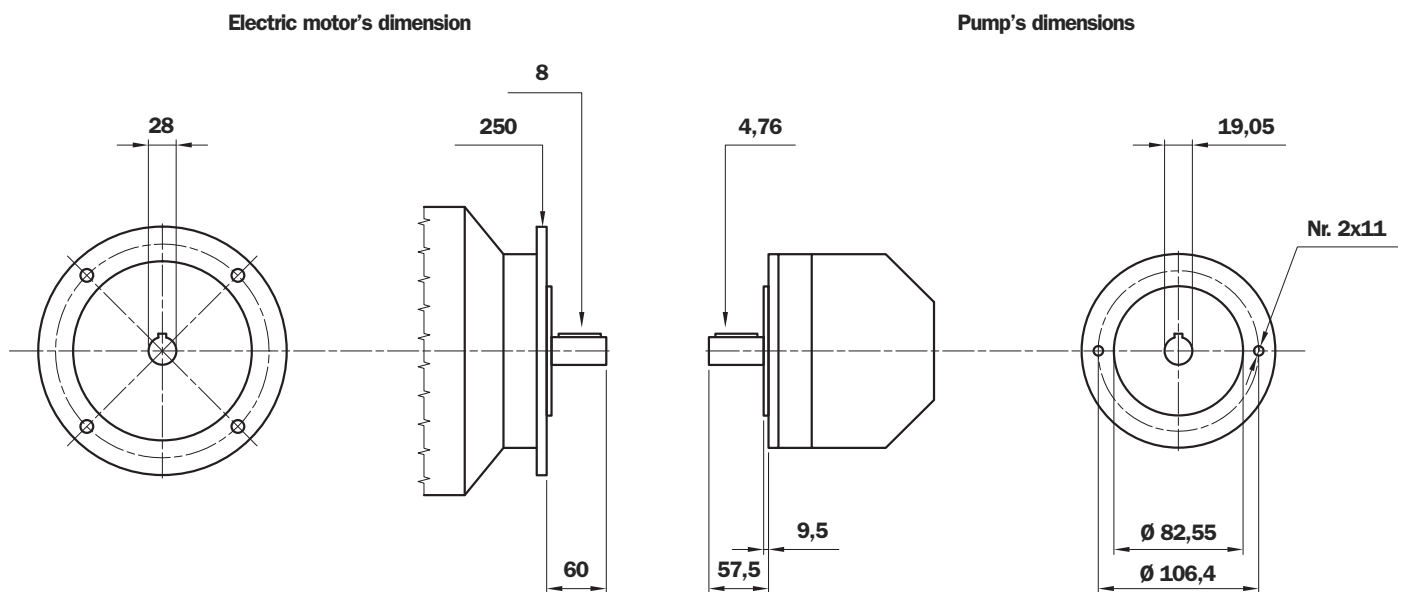

Bell-Housing's length calculation

- $H = 60 + 18 + 57,5 = 135,5$ mm (18= Sp spider - see page 49)
- Choose type of bell-housing (LMC - LMS)
 - For LMC see tab. 3 at page 11
 - For LMS see tab. 21 at page 32
 - For MODUL 2/3 see at page 36

Note: The length of bell-housing must be \geq than the length calculated (135,5 mm)

Case A - solution with LMC bell-housing

Tab. 3 at page 11 - for electric motor 2kW LMC 250
 LMC 250 bell-housing with height $\geq 135,5$ - LMC250AFSQ

- The bell-housing code must be completed with drilling pump code (see tab. 34 at page 47)
 For the specific case C= 101,6 - Nr. 2 holes M10: Code drilling 070
- Definitive bell-housing code **LMC250AFSQ070**

Case B - solution with LMS bell-housing

Tab. 21 at page 32 - for electric motor 2kW LMS 250
 LMS 250 bell-housing with height $\geq 135,5$ - LMS250AFSQ

- The bell-housing code must be completed with drilling pump code (see tab. 34 at page 47)
 For the specific case C= 101,6 - Nr. 2 holes M10: Code for. 070
- Definitive bell-housing code **LMS250AFSQ070**

Choose coupling

- **Motor half-coupling** (see tab. 37 at page 50)
 - For electric motor GR 100/112, the half-coupling is **SGEA21M05060**
- **Spider** (see tab. 35 - 36 at page 49)
 - For SGEA21, EGE2 - EGE2RR
(choose spider material on the base of the application, oil, temperature and cycle machine, etc.)
- **Pump half-coupling**
 - Choose the drilling code tab. 43 - 44 at page 53 for shaft 19,05 - Ch. 4,76 - code: **G01**
 - Half-coupling length = L BH length - THK Spider - THK Spigot
 $138 \text{ mm} - 60 - 18 - 9,5 = 50,5 \text{ mm}$
 - Choose the half-coupling's length on tab. 38 at page 50 $\leq 50,5 \text{ mm}$.
 - Availabe length for SGEA21= 50 mm
 - Code half-coupling code: **SGEA21G01050**

**Software for automatic calculation available on the web site
www.mpfiltri.com - tools - software**

AKA
AKM0320068

Pump
Manufacturer: ATOS
Pump type: PFE
Pump model: PFE31 Shaft 1

Electric Motor
N. Pole: 2P
Type: M3-B5
Size: 100-112
Sec: 3-4
Isp: 4-5,44

HYDRAULIC PUMP - Technical Data
L: 57.5
d: 19.05
Ch: 4.76
E: 9.5
H: 82.55
B: 106
W: 2
F: M20

ELECTRIC MOTOR - Technical Data
L: 60
H: 28
Fig: 256
Ch: 8

Coupling material: Aluminium Cast iron Allow alternative material

Result
Coupling: M01 - 21066
Drilling Pump: 5000
Pump Shaft: G01
Motor Shaft: M05

Result
Monobloc Bellhousing:
Modular Bellhousing:
Silenced Bellhousing:
Monobloc Bellhousing: Pump half-coupling with grub screw
For other solution please contact technical department
Modular Bellhousing: OK
Silenced Bellhousing: OK

CLICK HERE TO PROCEED

Note: For multi pumps we recommend to use a specific support on the base of the pump's dimensions and weight.

Half-coupling SGE*** series

The half-couplings series SGE*** allow secure transmission between the electric motor and the driven side; they are able to absorb shocks and vibration, in addition to compensating radial misalignment, angular and axial.

The assembly of the couplings can be horizontal/vertical, withstanding vibration and load reversals.

The complete range of couplings are extrapolated from the on-line software, with a length equal than the shaft on which must be mounted and they are completed with grub screw for fixing located on the key.

Available for cylindrical shaft with metric and imperial dimensions as well for splined shafts as per specification DIN, ISO and SAE.

Admissible misalignment radial, angular and axial

Max admissible radial misalignment

Half coupling	R (mm)
SGE * 01	0,5
SGE * 21	1,0
SGE * 31	1,0
SGE * 40	1,0
SGE * 51	1,5
SGE * 60	1,5
SGE * 80	2,0
SGE * 90	2,0

Max admissible angular misalignment

Half coupling	β (°)
SGE * 01	
SGE * 21	
SGE * 31	
SGE * 40	1,5°
SGE * 51	
SGE * 60	
SGE * 80	
SGE * 90	

Max admissible angular misalignment

Half coupling	A (mm)
SGE * 01	2,0
SGE * 21	2,5
SGE * 31	3,0
SGE * 40	3,5
SGE * 51	3,5
SGE * 60	3,5
SGE * 80	4,0
SGE * 90	5,0

Normative ATEX 94/9/CE

Half-couplings SGE*** series are available to use in hazardous area.

The couplings are certified according to ATEX 94/9/CE (ATEX 95).

Category certified 2G - area 1 and 2.

Other information available on our web site "www.mpfiltri.com".

MP Filtri couplings are developed with:

CAD 3D



FEM (calculation)



Drawings 3D available on website www.mpfiltri.com at section TOOLS/2D-3D COMPONENTS

The half-couplings SGE*** series are in conformity to normative **DIN 740/2**.
The max torque to transmit is always less than the max torque that the coupling can transmit.

Examples verification of the coupling

Torque transmitted by electric motor:

Mt: $9560 \times \text{kW} / \text{rpm} = \text{Nm}$

Me > $\text{Mt} \times \text{S} = \text{Nm}$

Where:

Mt: Torque transmitted by electric motor

Me: Torque transmitted by coupling (see table 14)

kW: Power of electric motor

Rpm: Revolutions per minute of electric motor

S: Service factor (see table 14)

TABLE 1

Small pumps, uniform load, low operating pressures e.g. rotary action machine tools - 5/8 work cycles per hour	1.3
Small pumps, uniform load, high working pressures e.g. lifting equipment - 120-150 work cycles per hour	1.5
Pumps, non-uniform load e.g. lifting equipment - 280-300 work cycles per hour	1.7

Example

Electric motor, 4 pole - 4 kW

hydraulic pump, uniform load, low operating pressure

Mt: $9560 \times 4 / 1500 = 25.45 \text{ Nm}$

Me > $25.49 \times 1.3 = 33 \text{ Nm}$

Half-coupling SGEA21 meets the above requirement.

Select the half-coupling of the calculated size from the motor half-couplings table.

Note: When selecting the coupling, remember that for pumps with splined shaft, only cast iron couplings of the SGEG series can be used.

Determine the size of the coupling according to the type of installation and application envisaged, on the basis of the following formulas and tables:

TABLE 2

Half-coupling type	External diameter mm	Nominal torque Me - Nm	Maximum transmissible torque Me - Nm	
ALUMINIUM	SGEA01	43	15	20
	SGEA21	68	160	190
	SGEA31	85	340	380
	SGEA51	109,5	550	620
CAST IRON	SGEG01	40	20	30
	SGEG30	80	400	450
	SGEG40	95	550	620
	SGEG60	120	760	850
	SGEG80	160	2200	2500
	SGEG90	200	5500	6100
STEEL	SGES40	95	550	620
	SGES60	120	760	850
	SGES80	160	2200	2500

Nominal and maximum torque values are referred to couplings assembled with standard flexible spiders of the **EGE**** series (see page 49).

Where higher torques are to be transmitted, use flexible spiders of the **EGE**RR** series (see page 49).

Noise

Noise is a particularly pervasive problem so much so that there have been statutory regulations in place now for some years, designed to limit harmful occupational exposure. Many of the machines used in industry today are equipped with oil-hydraulic systems, which happen to be a major source of noise.

1. Theory and definition of noise

From a health and hygiene standpoint, noise can be defined as an unpleasant and undesirable sound, or an unpleasant and annoying or intolerable auditory sensation (noise being any sound phenomena that may be accompanied by sensations of disturbance and pain). By definition, acoustic phenomena are oscillatory in character, propagated in a flexible medium and causing pressure variations at the points, and the areas adjacent to those points, through which they pass.

2. Sound

Technically considered, certain elements must be present simultaneously for acoustic phenomena to occur:

- Sound source
- Transmission medium
- Receiver

Motor and pump unit

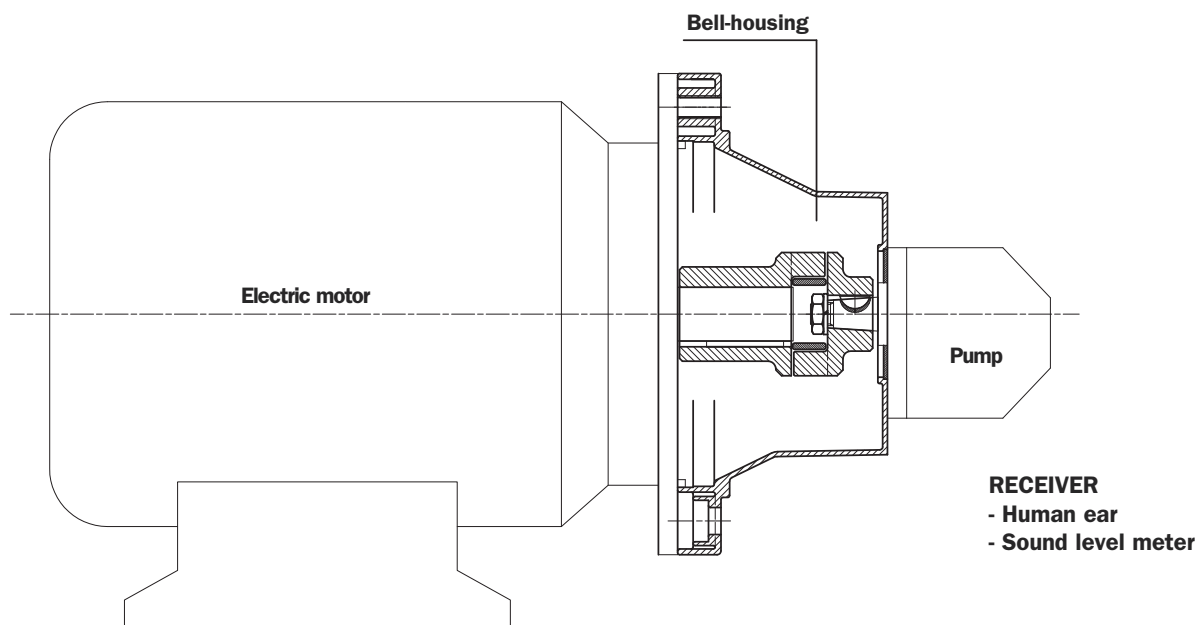

The **electric motor** and the **pump**, together with the drive coupling, are the **SOURCE OF THE NOISE**.

The **Bell-housing** is the noise transmission medium.

Depending on whether the monobloc bell-housing is a rigid or low noise type, there will be variations in the flexible properties of the transmission medium.

The acoustic phenomena are dissimilar in the two cases, given the differences in pressure variation and particle displacement.

Assembly of motor and pump unit

As mentioned in the presentation, low noise bell-housing will help to attenuate the transmission of vibrations and the emission of noise generated by the system.

Self-evidently, however, the mere adoption of a low noise bell-housing will achieve little unless the motor and pump are correctly installed on the machine, or on the tank of the hydraulic power unit.

- Should be followed in order to achieve best possible results and correct installation:

1. Motor and pump unit mounted horizontally on oil tank lid

- The suction pipe attached to the pump must be rigid, and fitted using a resilient bulkhead flange of the FTA series, which helps to cushion the vibrations propagated between the pipe and the tank lid. If pipes need to be bent, the radius of curvature must be at least 3 times the pipe diameter. Do not use elbow fittings, as these will significantly increase pressure losses.
- The pressure pipeline of the pump must be flexible, and long enough to include bends with the minimum radius of curvature recommended by the manufacturer for the specified operating pressure.
- The return pipeline running from the service to the filter must be flexible. Where oil is returned directly to the tank of the hydraulic power unit through a rigid pipe, it is advisable to use a resilient bulkhead flange of the FTR series, which helps to cushion the vibrations propagated between the pipe and the tank lid.
- Anti-vibration devices (resilient mounts or damping rods) must be located under the feet of the electric motor or the PDM foot brackets, depending on the mounting position of the motor.
- The lids of hydraulic oil tanks must be sturdy enough to support the load they carry.

2. Motor and pump unit mounted horizontally on machine

- As a matter of good practice, the oil tank and motor-pump unit should be mounted on a single supporting frame of strength sufficient to support the load.
- If the hydraulic system is fitted with a side-mounted filter, the suction pipeline to the pump must be flexible, and long enough to include bends with the minimum radius of curvature recommended by the manufacturer.
- If the suction filter is not side mounted, the pipeline should be rigid and installed in conjunction with a compensating coupling.
- The pressure pipeline of the pump must be flexible, and long enough to include bends with the minimum radius of curvature recommended by the manufacturer for the specified operating pressure.
- The return pipeline running from the service to the filter must be flexible. Where oil is returned directly to the tank of the hydraulic power unit through a rigid pipe, it is advisable to use a resilient bulkhead flange of the FTR series, which helps to cushion the vibrations propagated between the pipe and the tank lid.
- Anti-vibration devices (resilient mounts or damping rods) must be located under the feet of the electric motor or the PDM foot brackets, depending on the mounting position of the motor.

Note: The above guidelines are indicative only, and subordinate to the solutions adopted ultimately by design engineers.

In conclusion: For best results, in any event, the motor-and-pump unit should be incorporated into the hydraulic system in such a way that no one component is rigidly associated with another, resulting in the propagation of vibration, and consequently noise.

Table of summary MODUL 2/3

	5.5 - 7.5 kW	11 - 22	30	37 - 45	55 - 90	110 - 200	250 - 400
	7.5 - 10.2 Hp	15 - 30 Hp	40.80 Hp	50.32 - 61.2 Hp	75 - 125 Hp	150 - 272 Hp	340 - 544 Hp
	Size 225 - D.450	Size 160/180 D.350	Size 200 - D.350	Size 225 - D.450	Size 250/280 D.550	Size 315 - D.660	Size 355/400 D.800
MODUL 2	<p>AR*</p> <p>BMT300 BMT350</p> <p>FR1*</p> <p>Kit of assembly KVG5 (Q.ty 1) + Kit of assembly KVG1 (Q.ty 1)</p>						
	<p>AD*</p> <p>BMT350 BMT400 BMT450</p> <p>FP5 FP6 FP7</p> <p>Kit of assembly KVG5/7 (Q.ty 2)</p>						
MODUL 3	<p>BMT550 BMT660 BMT800</p> <p>FP6 FP7 (BAD800 ONLY FP7)</p> <p>Kit of assembly KVG6/7 (Q.ty 1)</p>						
	5.5 - 7.5 kW	11 - 22	30	37 - 45	55 - 90	110 - 200	250 - 400
7.5 - 10.2 Hp	15 - 30 Hp	40.80 Hp	50.32 - 61.2 Hp	75 - 125 Hp	150 - 272 Hp	340 - 544 Hp	340 - 544 Hp
Size 225 - D.450	Size 160/180 D.350	Size 200 - D.350	Size 225 - D.450	Size 250/280 D.550	Size 315 - D.660	Size 355/400 D.800	Size 355/400 D.800

Modular bell-housing components

MODUL 2/3

Modular bell-housing components are used to connect **UNEL-MEC electric motors with B3 - B5** flanges to piston, vane and screw type hydraulic pumps.

The advantage of modular design is that a wide range of motor and pump combinations can be covered with relatively few components.

This means that dealers can simplify their inventory while still being able to service the majority of applications envisaged.

The strength of these components will also guarantee top reliability, even in the toughest of applications.

Suitable for electric motors from **size 132, rated 5.5 kW**, up to **size 400, rated 400 kW**.

Technical specifications

MODUL 2/3

Materials

- **Base module**
Pressure diecast aluminium alloy.
- **Pump flange**
Alluminium alloy.
- **Intermediate adapter**
Alluminium alloy.
- **Foot bracket**
Pressure diecast aluminium alloy.
- **Gaskets**
Special paper (guarnital).

Temperature

- $-30^{\circ}\text{C} \div +80^{\circ}\text{C}$
For temperatures outside this range,
contact the MP Filtri Technical and Sales Department.



Compatibility with fluids

- **Modular bell-housing components compatible for use with:**

Mineral oils

Types HH-LL-HM-HR-HV-HC, to ISO 6743/4 standard

Water based emulsions

Types HFAE - HFAS, to ISO 6743/4 standard

Water glycol

Type HFC, to ISO 6743/4 standard

Ask for anodized version

Special Applications

- **Any applications not covered by the normal indications contained in this catalogue must be evaluated and approved by the MP Filtri Technical and Sales Department.**

Mounting components

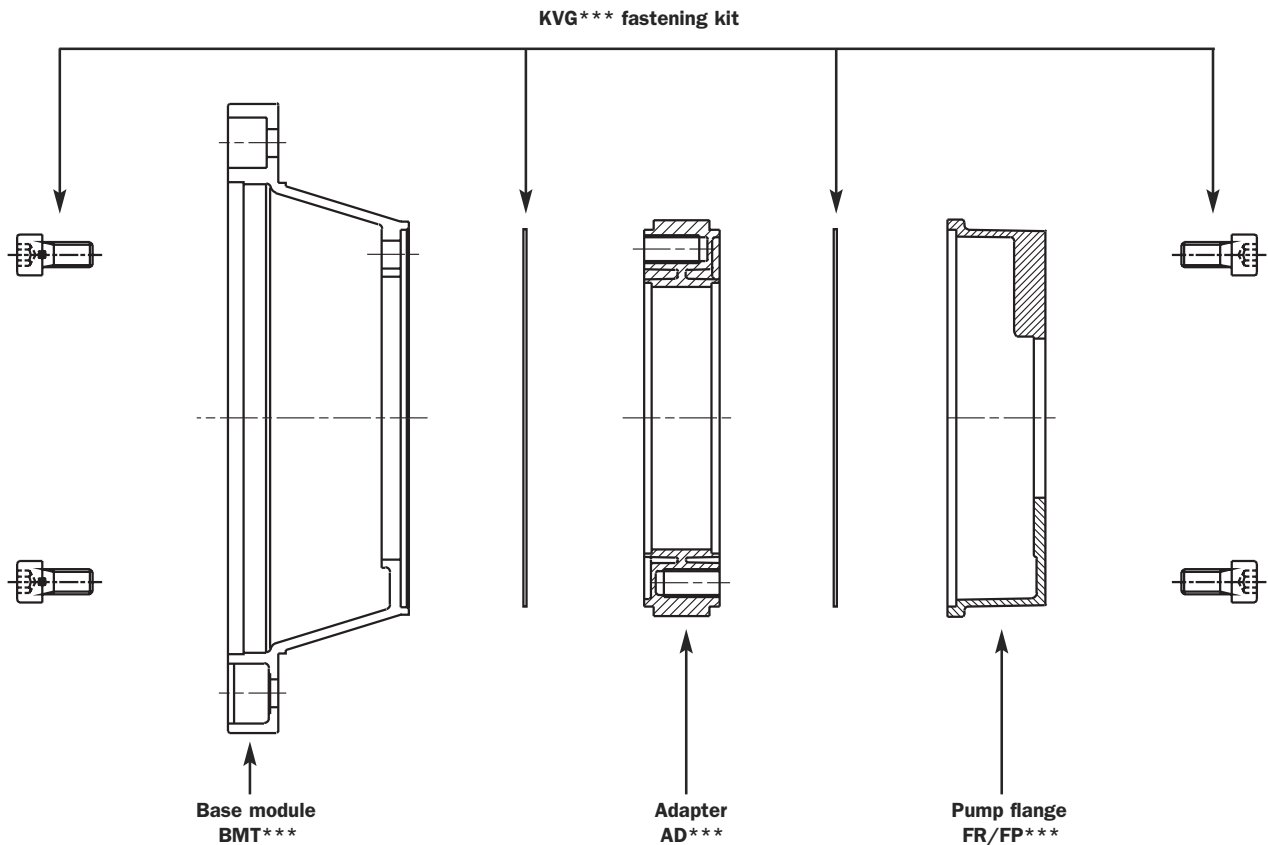

- 1 Clean the gasket seating surfaces
- 2 Locate the base module gasket in the relative recess and position the adapter
- 3 Secure with the bolts of the kit
- 4 Locate the pump flange gasket in the relative recess, then offer the flange to the adapter
- 5 Secure with the bolts of the kit

Note: Secure the screws of the fastening kit as indicated in the following table

Recommended tightening torques for assembly of components.

KVG 1	KVG 5	KVG 6	KVG 7
M8	M14	M16	M20
24 Nm	135 Nm	205 Nm	400 Nm

These values are calculated to exploit the performance of the bolt at 70% of its elastic limit.

This means in practice that the shank of the bolt will be stressed typically to 60-70% of its limit of elasticity in the course of being tightened.

The values indicated are valid for hexagon head bolts to UNI 5737 and hexagon socket screws to UNI 5931, property class 8.8, tightened by degrees using a torque wrench.

If bolts or screws are tightened using impact or hammer action drivers, the figure indicated should be reduced by 10%.

.....

.....

.....

.....

.....

.....

.....

.....

Motor base

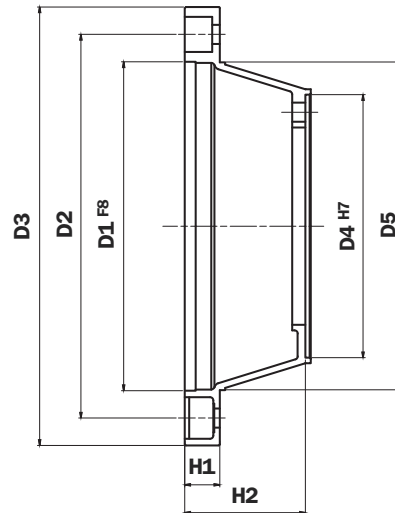
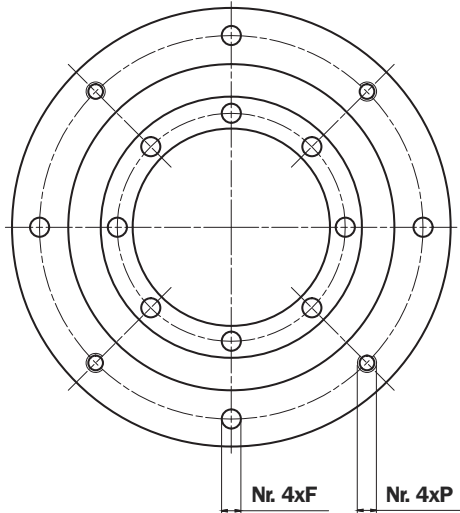

TABLE 23 - MODUL 3

Motor 4-pole 1500 rpm				Dimensions of motor base													
Frame size	kW	Hp	Shaft	Code	Foot bracket code	D1	D2	D3	D4	D5	H1	H2	F.	Nr.	P	Nr.	Weight (kg)
132	5.5-7.5	7.5-12.5	38x80	BMT300A0805	PDM A 300	230	265	300	190	234	24	80	M12	4	14	4	1,95
160	11-15	15-20	42x110	BMT350A1105	PDM A 350	250	300	350	190	260	32	110	M16	4	18	4	3,10
180	18.5-22	25-30	48x110	BMT350A1105	PDM A 350	250	300	350	190	260	32	110	M16	4	18	4	4,90
200	30	40	55x110	BMT400A1106	/	300	350	400	240	300	32	110	M16	4	18	4	4,90
225	37-45	50-60	60x140	BMT450A1406	/	350	400	450	240	350	32	140	M16	8	/	/	5,00

For dimension see page 55

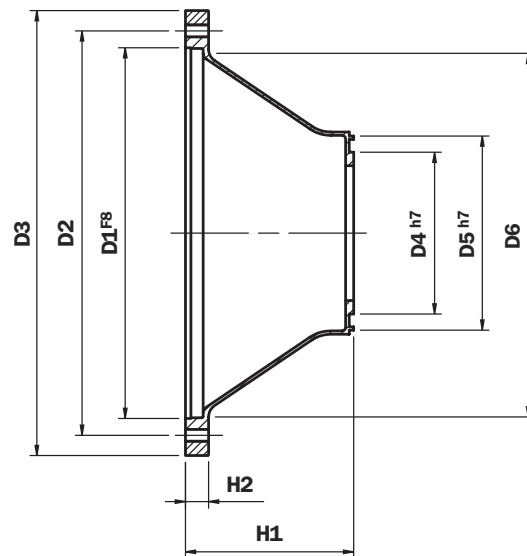
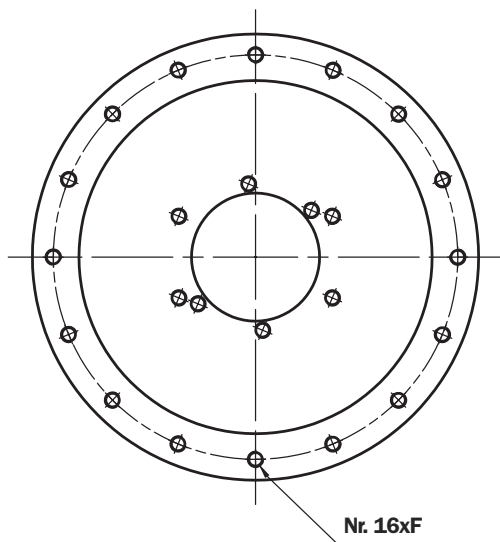

TABLE 24 - MODUL 2

Motor 4-pole 1500 rpm				Dimensions of motor base														
Frame size	kW	Hp	Shaft	Code	Foot bracket code	D1	D2	D3	D4	D5	D6	H1	H2	F.	Nr.	P	Nr.	Weight (kg)
250	55	75	65x140	BMT550A21567	/	450	500	550	240	288	450	215	32	M16	16	/	/	8,40
280	75-90	100-125	75x140	BMT550A21567	/	450	500	550	240	288	450	215	32	M16	16	/	/	8,40
315	110-200	100-125	80x170	BMT660A25067	/	550	600	660	240	288	550	250	40	M20	16	/	/	12,00
355	250-315	340-428	95x170	BAD800A2707	/	680	740	660	288	/	680	270	40	M20	8	/	/	31,00
400	355-400	483-544	100x210	BAD800A2707	/	680	740	800	288	/	680	270	40	M20	8	/	/	31,00

Not available

Intermediate adapter

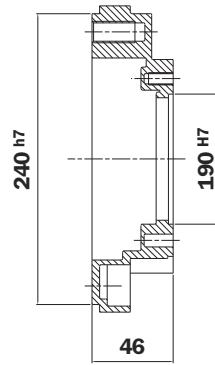

TABLE 25

Application with Motor base	Application with Pump Flange	Code Adapter	Fastening kit Motor base	Fastening kit Pump Flange	Weight (kg)
BMT400A1106 BMT450A1406	FP6 *** **	AD60465	KVG6	KVG5	1,30

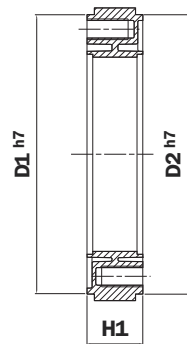

TABLE 26

Application with Motor base	Application with Pump Flange	Code Adapter	Fastening kit Motor base	Fastening kit Pump Flange	D1	D2	H1	Weight (kg)
BMT300A0805 BMT350A1105	FP5 *** **	AD50385	KVG5	KVG5	190	240	38	1,00
BMT400A1106 BMT450A1406	FP6 *** **	AD60466	KVG6	KVG6	240	288	46	1,60

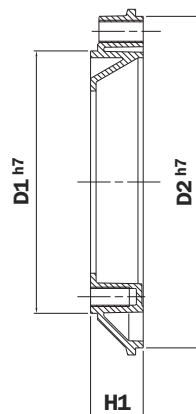

TABLE 27

Application with Motor base	Application with Pump Flange	Code Adapter	Fastening kit Motor base	Fastening kit Pump Flange	D1	D2	H1	Weight (kg)
BMT300A0805 BMT350A1105	FP5 *** **	AD50386	KVG5	KVG6	190	240	38	1,25
BMT300A0805 BMT350A1105	FP5 *** **	AD50467	KVG5	KVG7	190	288	46	1,90
BMT400A1106 BMT450A1406	FP6 *** **	AD60467	KVG6	KVG7	240	288	46	2,50

Pump flange

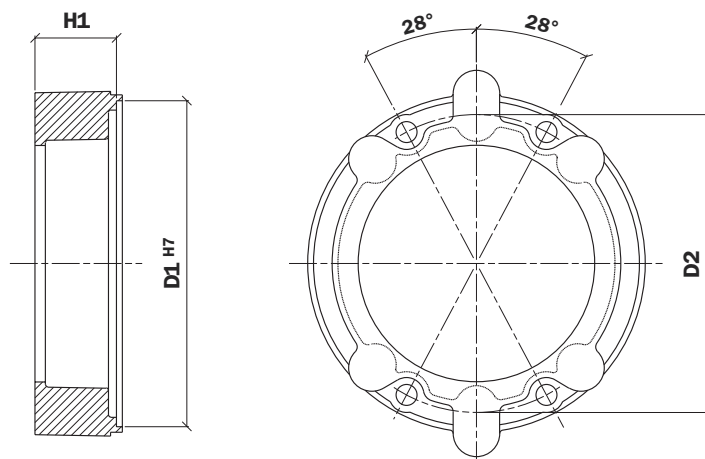

TABLE 28

Code	Flange			Assembly kit	Possible pump interfaces	Weight (kg)
	H1	D1	D2			
FR1023***	23	85	105	KVG1	S024 S025 D042 S061 S063 S083 S023 S070 S071 S072 S075 S125 S154	0,25
FR1025***	25				S021 S026 S068 S069 S080 S082 S115 S237	0,30
FR1033***	33				S021 S023 S026 S027 S070 S071 S072 S074 S080 S082 F260	0,80
FR1035***	35				S060 S063 S065	0,90
FR1040***	40				S098 S227	1,10
FR1079***	79				S031 S116	1,30

TABLE 29

Code	Flange			Assembly kit	Possible pump interfaces	Weight (kg)			
	H1	D1	D2						
FP5026***	26	190	170	KVG5	S023-S024-S025-S033-D042-S063-S070-S072-S075-S154-S254	1,00			
FP5032***	32				S024-S031-S158-S096-S125	1,10			
FP5035***	35				S021-S023-S024-S025-S026-S031-S059-S060-S068-S072-S074-S075-S083-S097-S106-S125-S131-S138	0,90			
FP5045***	45				S021-S024-S025-S026-S060-S068-S070-S071-S072-S074-S075-S106-S125-S141	0,90			
FP5056***	56				S021-S026-S072	1,61			
FP5063***	63				S021-S025-S068-S070-S079-S138-S141	1,70			
FP5064***	64				S024-S025-S059-S093-S099-S100-S104	1,70			
FP5091***	91				S025-S031-S033-S100-S113-S115-S116-S267	2,20			
FP6032***	32				240	218	KVG6	S021-S035-S081-S082	1,80
FP6045***	45	S021-S025-S026-S027-S069-S070-S075-S077-S080-S081-S082-S125-S198-S207-S215-S253	2,10						
FP6058***	58	S024-S025-S026-S027-S038-S077-S078-S079-S080-S081-S082-S207-S215-S237	2,40						
FP6070***	70	S080-S270	3,00						
FP6082***	82	S038-S080-S081-S116-S141-S198-S215	3,30						
FP6086***	86	S021-S026-S027-S077-S078-S090-S092-S166-S091-S114-S132-S198-S200	3,40						
FP6101***	101	S027-S035-S113-S115-S132-S148-S176-S228	4,20						
FP6110***	110	S080-S111	5,50						
FP7052***	52	288	258	KVG7				S028-S092-S108-S112-S133-S192	4,10
FP7066***	66							S090-S092-S166	4,75
FP7069***	69				S108-S143-S148-S158-S192-S19-S201-S204-S281-S282-S288	4,90			
FP7086***	86				S022-S027-S028-S091-S092-S108-S112-S117-S166-S184-S192-S201-S228-S300	5,20			
FP7111***	111				S028-S091-S112-S117-S144-S145-S184	6,30			

Complete the order designation with the pump interface code: Ex. **FP5026S023**

Monobloc bell-housing for NEMA motors

Monobloc bell-housings for NEMA motors are standard products of the LMC series used normally for electric motors manufactured to European standards.

These bell-housings must be used in combination with specific **ADNEMA 143 TD** and **ADNEMA 254 TD** adapters.

For dimensions and clearances of adapter rings see page 45.

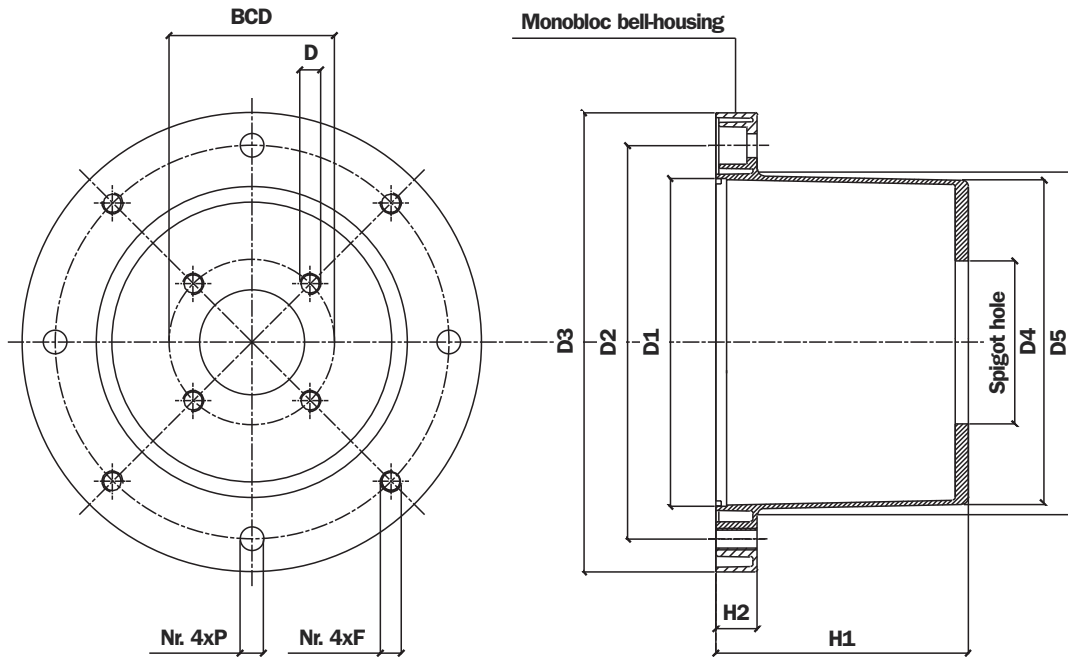

The auxiliary flange, if specified, is supplied already fitted to the bell-housing (MODUL-2).

- Check that the pump interface dimensions are compatible with those of the bell-housing

Note: The hole made in the tank cover should be 2 mm larger than dimension D5

Machining tolerances

D1	F8
Spigot hole	H7
H1	± 0,15 mm

Concentricity of D1/Spigot hole

LMC 300	0,20 mm
---------	----------------

TABLE 30

Bell-housing code	Dimensions of LMC monobloc bell-housing									
	Foot bracket code	D1	D2	D3	D4	D5	H1	H2	F	P
LMC 300AFST***	PDM A 300	230	265	300	230	235	155	23	M12	14
LMC 300AFSX***	PDM A 300	230	265	300	230	235	170	23	M12	14
	For dimension see page 55									

Base module for NEMA motors

BMC series motors base are derived from standard LMC monobloc bell-housings and used as base elements to which **FR/FP5/FP6** series auxiliary flanges can be fixed so as to increase the height of the bell housing or allow the attachment of a pump, which would not be possible using a monobloc bell housing.

Motors base can be used for the installation of NEMA motors in conjunction with specific **ADNEMA 143 TD** and **ADNEMA 254 TD adapters**. For dimensions and clearances of adapter rings, see page 45.

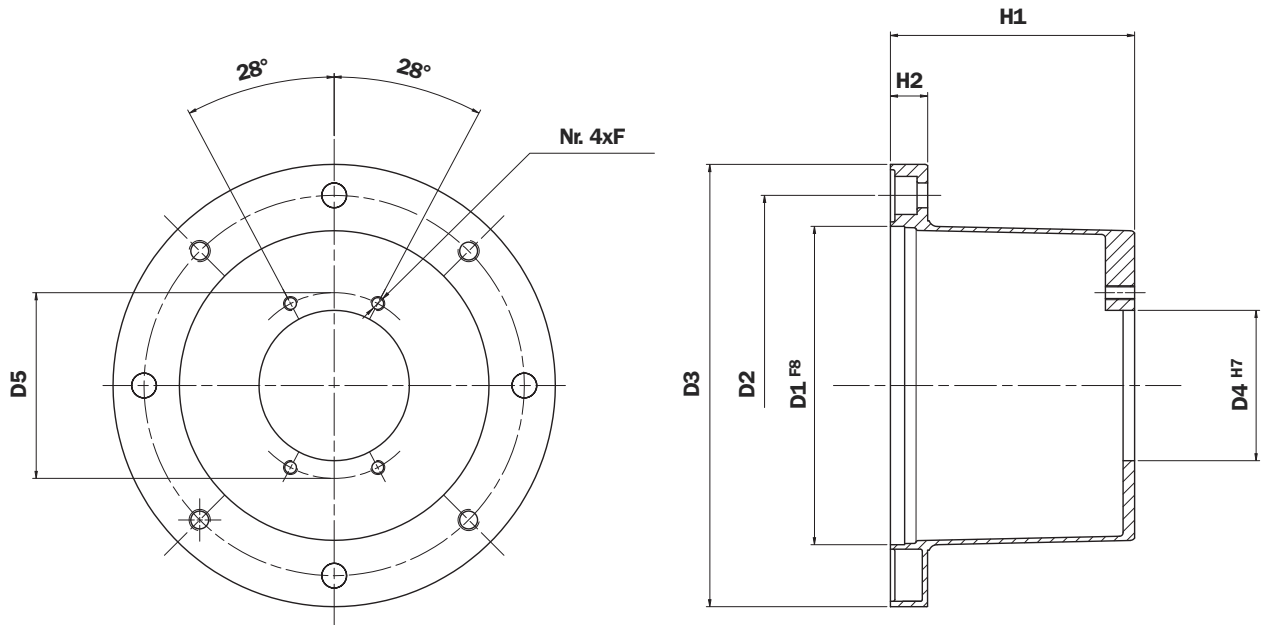

TABLE 31

		Dimensions of BMC motor base								Weight (kg)
Motor base code	Foot bracket code	D1	D2	D3	D4	D5	H1	H2	F	
BMC300A1551	PDM A 300	230	265	300	85	105	155	23	M8	3,30
BMC300A1701	PDM A 300	230	265	300	85	105	170	23	M8	3,30
BMC300A1555	PDM A 300	230	265	300	170	218	155	23	M14	3,30
BMC300A1705	PDM A 300	230	265	300	170	218	170	23	M14	3,30

For dimension see page 55

• For pump flange codes, see page 17

Low noise bell-housing for NEMA motors

Low noise bell-housings for NEMA motors are standard products of the LMS series used normally for electric motors manufactured to European standards.

These bell-housings must be used in combination with specific **ADNEMA 143 TD** and **ADNEMA 254 TD** adapters. For dimensions and clearances of adapter rings, see page 45.

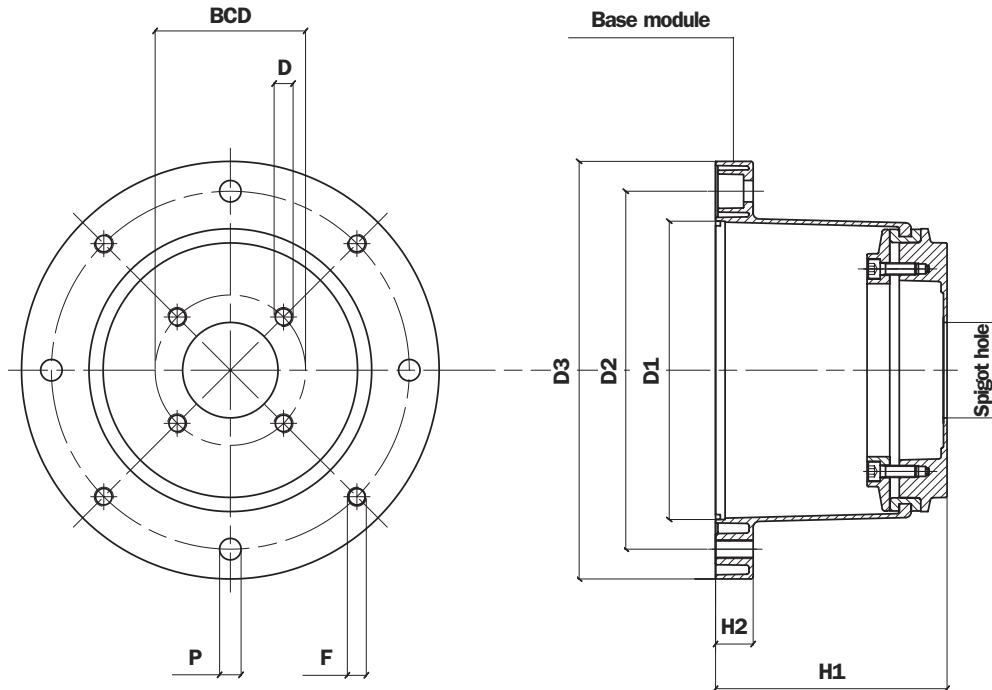

- The auxiliary flange, if specified, is supplied already fitted to the bell-housing.

N.B. In order to ensure coaxial alignment between the motor and pump spigot centres, the bell-housing cannot be disassembled and reassembled.

Machining tolerances

D1	F8
Spigot hole	H7
H1	± 0,15 mm

Concentricity of D1/Spigot hole

LMS 300	0,20 mm
---------	---------

TABLE 32

Dimensions of LMS low noise bell-housing								
Bell-housing code	Foot bracket code	D1	D2	D3	H1	H2	F	P
LMS 300AFSC***	PDM A 300	230	265	300	155	23	M12	14
LMS 300AFSD***	PDM A 300	230	265	300	168	23	M12	14

For dimension see page 55

Motor base for NEMA motors - Flange TD

Motors base for NEMA motors are standard products of the BMT series used normally for electric motors manufactured to European standards, which are machined in such a way as to provide the necessary interface for the NEMA motor. Motors base are utilized in conjunction with standard pump flanges of the FP series. For the dimensions of flanges, see page 17.

**Motor base for NEMA motors:
404TD - 405TD - 444TD - 445TD - 447TD - 449TD**

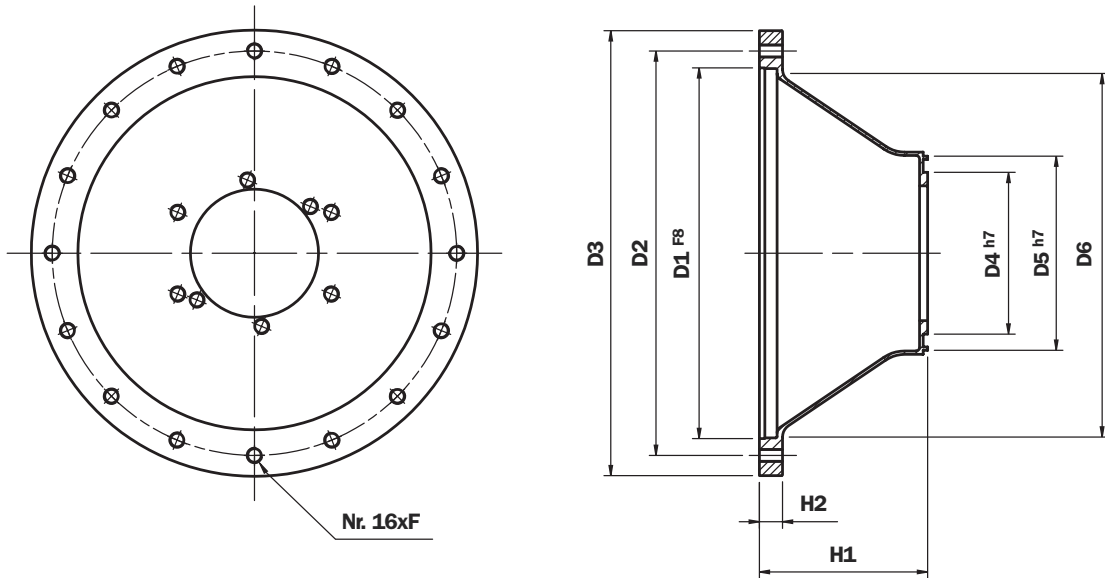
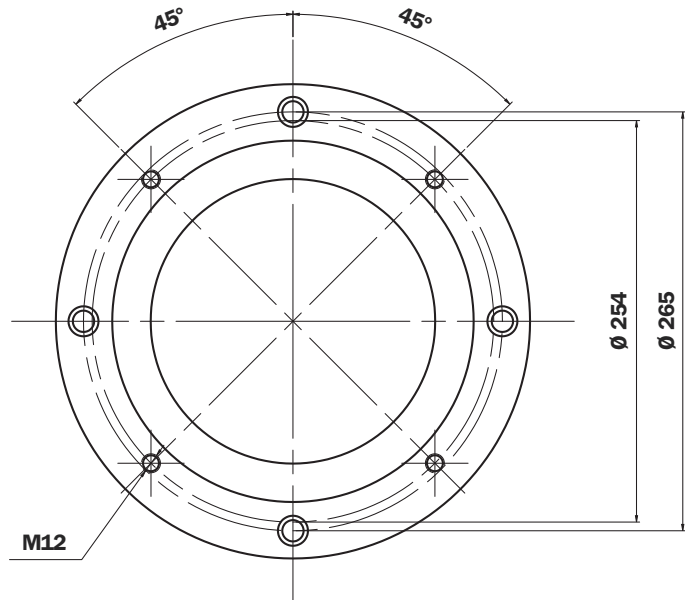
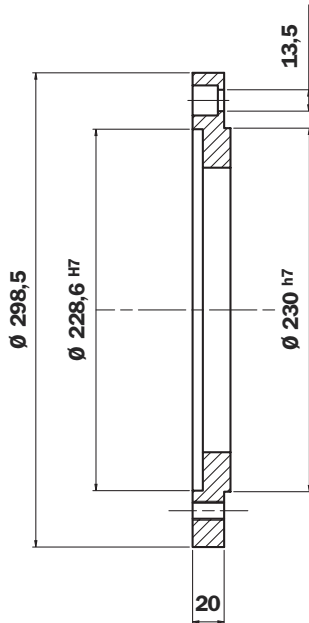

TABLE 33 - MODUL 2

Dimensions of Motor base										
Code	D1	D2	D3	D4	D5	H1	H2	F.	Nr.	Weight (kg)
BMT450NEMA324TD	355,6	406,4	450	240	350	140	32	18	8	5,00
BMT550NAMA404TD	457,2	508	550	240	450	215	32	18	16	8,40

Adapters for NEMA motors - Flange TD

Adapter for NEMA motors NEMA: Cod. ADNEMA143TD
143TD - 145TD - 180TD - 182TD - 184TD - 210TD - 213TD - 215TD
To assemble on bell-housing LMC - BMC - LMS - BMT 300



Adapter for NEMA motors NEMA: Cod. ADNEMA254TD
256TD - 284TD - 286TD

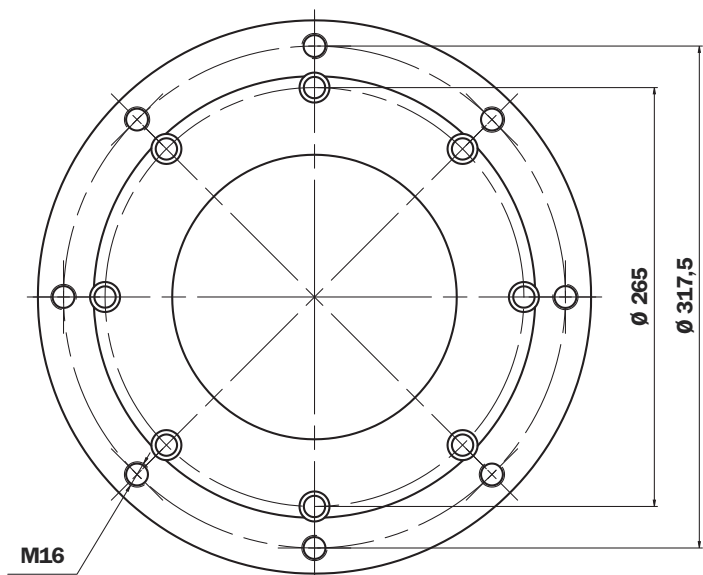
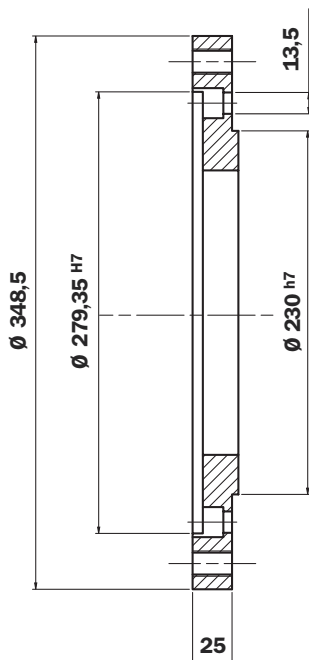

LMC series steel bell-housings

These bell-housings made of welded steel are available for electric motors rated from 0.5 up to 1000 kW, responding to UNEL-MEC (European) and to NEMA (US) standards. The dimensions can be customized to suit the type of motor-pump combination, or to meet particular customer specifications.

Standard finishes:

- zinc-treated, white
- oil-resistant primer, black

Custom treatments or paint finishes can be applied on request.

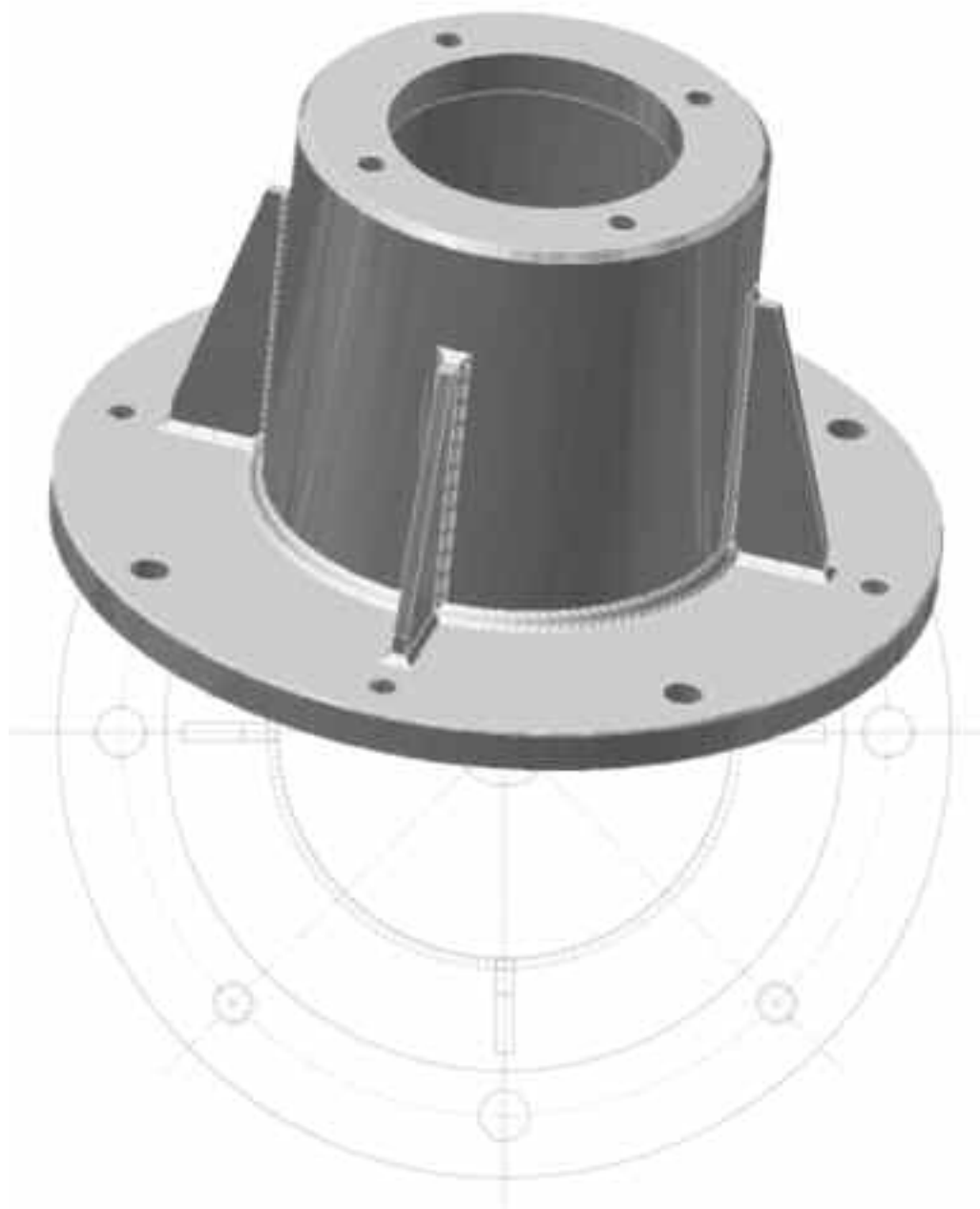
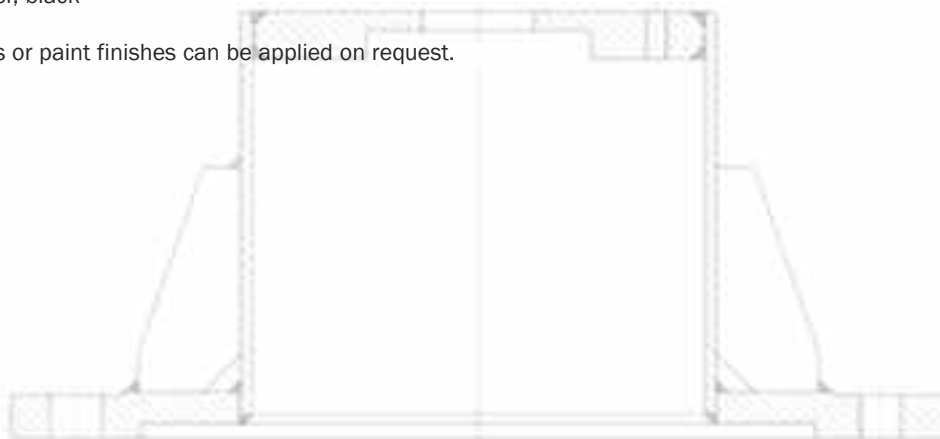

Pump interface codes

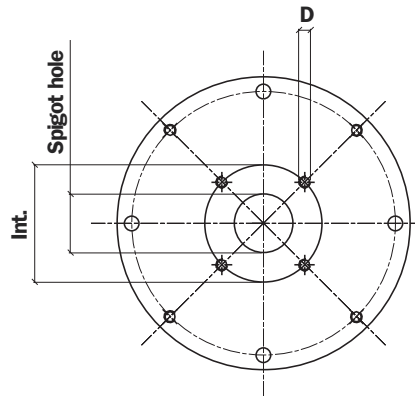
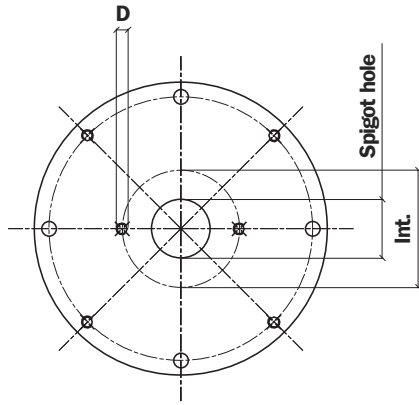

• 2 x hole at pump interface, aligned with through holes at motor interface

• 4 x hole at motor interface, aligned with through holes at motor interface

TABLE 34

Spigot hole mm	BCD	D	N° holes	Code
40	72	M8	2	191
45,2	88,9	M8	4	096
	71,8	M8	4	120
50	80	M8	2	052
	93	M10	2	053
	60	M5	4	280
	63	Ø7	4	057
50,8	93	M8	2	287
	82,50	M8	2	050
52	/	/	/	/
56	/	/	/	/
	76	M6	4	234
57,15	106,4	Ø11	2	212
60	74	M10	4	098
	98,5	M6	4	147
	75	M6	4	227
62,7	157,2	M12	4	231
63	100	M8	2	042
	125	M6	4	043
	160	M8	4	044
	80	M8	2	051
65	80	Ø8,5	4	058
	100	M10	2	062
	85	M8	4	168
	90	M8	4	271
70	84	Ø7	4	289
71,8	88,9	M10	4	047
75	102	M10	4	139
80	100	M8	4	024
	103,2	M8	2	045
	100	Ø11	4	059
	100	M10	2	061
	110	M10	2	063
	140	M10	2	064
	115	M10	2	065
	100	M10	4	067
	106,4	M10	2	083
	130	M8	4	087
	100	Ø8,5	4	093
82,55	113	M12	4	104
	95	M8	4	169
	103	M8	4	242
	110	M10	4	272
	106,4	M10	2	060
	105	M10	4	097
	106,4	M8	2	254
85	146	M12	2	260
	110	M10	2	284
90	112	M8	2	134
90	105	M8	4	156
	118	Ø9	2	163
	112	Ø9	2	164

Spigot hole mm	BCD	D	N° holes	Code
92	140	M8	4	088
	145	M10	4	089
95	115	M8	4	137
95,2	127	M10	4	131
98,4	125	Ø11	4	128
100	125	M10	2	023
	125	M10	4	025
	125	Ø11	4	031
	125	Ø11	4	032
	190	Ø15	4	038
	125	Ø13	4	041
	125	M12	2	071
	140	M12	2	072
	146	M12	2	075
	126	M10	2	106
	120	M8	4	122
101,6	160	M10	4	141
	150	M10	4	150
	161,5	M12	4	029
	146	M12	2	070
	127	M12	4	125
	146	M10	2	159
	127	M10	4	224
105	146	M12	2	076
110	175	M10	4	110
	130	M8	4	154
	200	M10	4	202
	135	M10	4	219
112	145	M12	4	273
	140	M12	2	074
	140	M10	2	138
115	130	M10	4	264
	180	M12	4	198
116	160	M14	2	084
120	210	M16	2	094
	145	M10	4	155
	150	Ø13	4	267
125	160	M12	4	026
	160	Ø13	4	033
	160	M12	2	079
	180	M16	2	082
	155	M10	4	102
	160	Ø17	4	113
	200	M12	4	114
	181,2	M16	2	136
	200	M16	4	200
	180	Ø20	4	215
	170	Ø18	4	237
127	161,5	M12	4	021
	181,2	M16	2	080
	161,5	M14	4	140
130	165	Ø11	4	054
	150	M12	4	068
	181,2	M16	2	085
	165	M12	4	124
	165	M14	4	135

Spigot hole mm	BCD	D	N° holes	Code
130	165	M10	4	253
135	160	M10	4	151
	175,4	M12	4	220
140	180	M140	4	077
	180	M12	2	281
	165	M10	4	157
	200	M16	4	176
	165	M10	4	223
150	180	M16	2	232
	185	M16	4	069
152,4	228,6	M16	4	022
	228,6	M18	2	090
	228,6	M18	41	108
	217,5	Ø17	4	118
	228,6	M20	2	166
	228,6	M20	4	192
	190,5	M8	4	207
160	200	M16	4	027
	200	Ø17	4	035
	200	M16	2	091
	224	M20	2	092
	200	M12	2	107
	230	M22	4	111
	185	M12	4	152
162	224	M16	4	184
	230	22	4	228
	188	M12	4	263
	317,35	M20	4	143
165,1	317,35	M24	2	145
	229	M20	4	201
	317,35	M18	4	204
	200	M12	4	153
175	230	M18	2	185
	350	M24	4	146
177,8	216	M12	4	222
	350	M24	4	203
	216	13	4	055
	216	M16	4	078
180	224	M16	4	112
	216	M12	4	132
	215	M22	4	148
	230	22	4	226
	250	M20	4	028
200	250	Ø22	4	095
	280	M24	2	117
	230,5	M12	4	214
203,2	254	M14	4	210
205	240	M16	4	133
224	280	M20	4	144
	280	Ø22	4	205
250	310	M24	4	238
	315	M20	4	282
275	355	M16	4	233
	355	Ø18	4	281
	-	-	-	-